



morton.

Pyrmont 40/209 Harris Street

 2  2  1

Displaying a sleek modern blend of generous design, stylish finishes and effortless in/outdoor living, this well-appointed two-bedroom apartment is a light filled urban haven with an expansive outdoor area. It has been designed to embrace low maintenance living and easy entertaining, plus it offers a very peaceful retreat of light and privacy with all of Pyrmont's amenities at your fingertips.



- Ideally tucked away in a quiet rear-of-the-building position
- A bright and airy open layout with lounge and dining spaces
- Courtyard-sized wraparound terrace with a sheltered BBQ area
- Two double bedrooms that both have built in wardrobes
- Modern gas kitchen, ensuite, full bathroom and internal laundry
- Shared rooftop terrace with views over Pyrmont and White Bay
- Secure basement car space plus own lock-up storage cage
- Onsite gymnasium, visitor parking and full building security

View



As advertised or by appointment

Agents

James Crow

 0410 593 057
 james@morton.com.au

Sarah Li

 0439 528 933
 sarahli@morton.com.au

morton.com.au

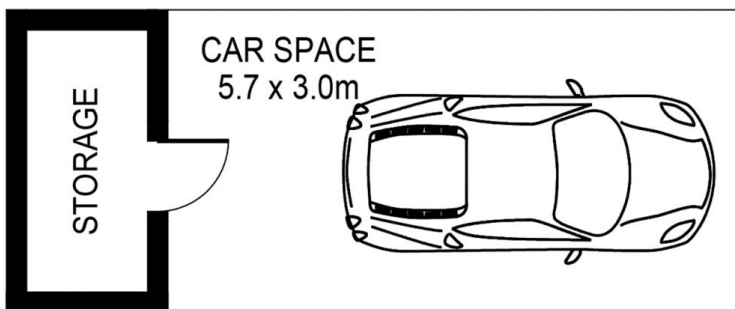
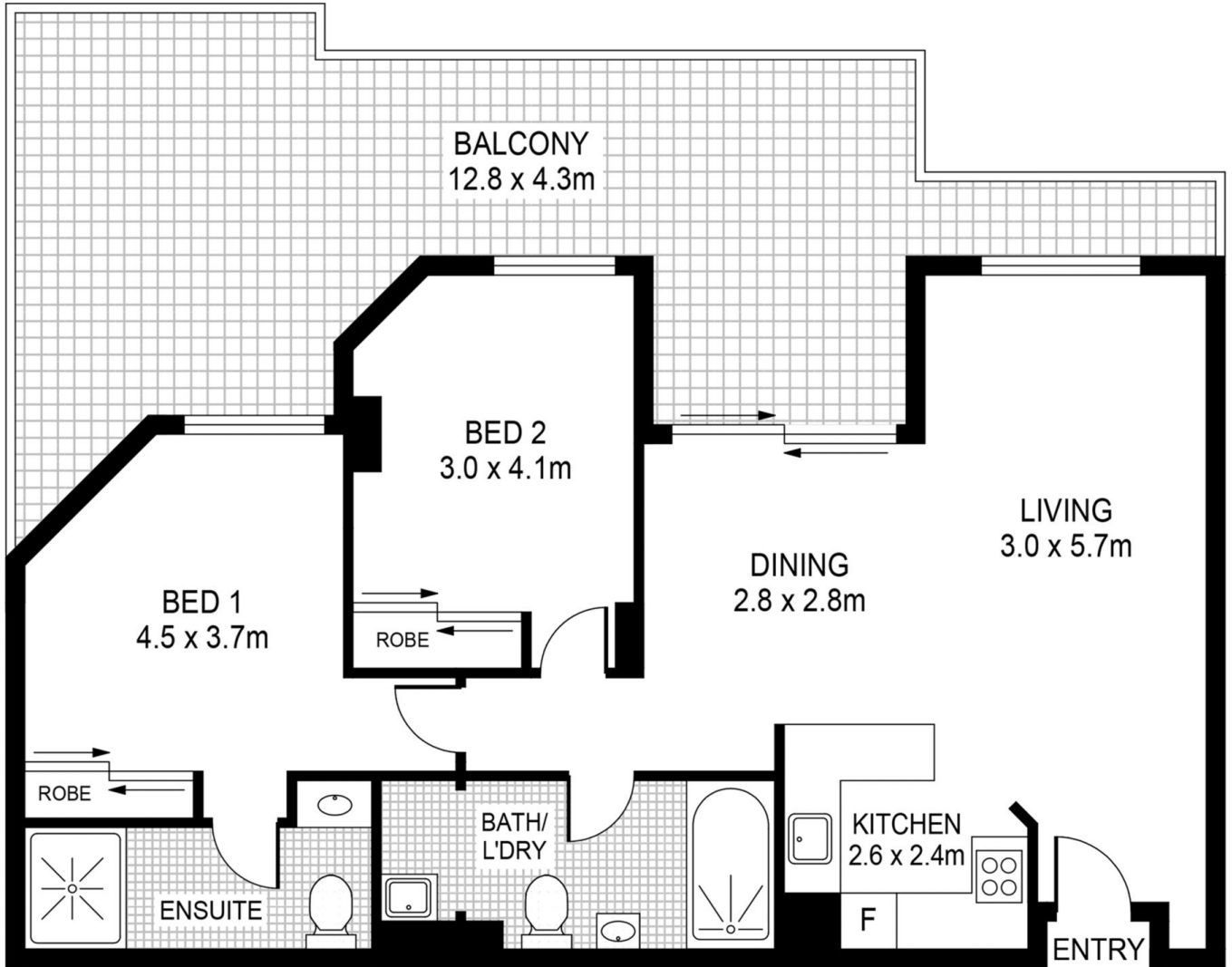

40/209 Harris St PYRMONT



This floor plan including furniture, fixture measurements and dimensions are approximate and for illustrative purposes only. Image Mountain gives no guarantee, warranty or representation as to the accuracy and layout. All enquiries must be directed to the agent, vendor or party representing this floor plan.