



morton.

Macquarie Park 5/6 Tuckwell Place

 2  1  2

Set quietly in leafy surrounds, this private double brick townhouse with a tranquil outlook is offered for the first time in 36 years. Immaculately maintained throughout, this offers comfortable and convenient living as well as an opportunity to update and add your own touch and further value.

- Large bedrooms each with built-ins, main with wrap around balcony
- Well-proportioned renovated kitchen; separate laundry
- Open plan living flows out to the courtyard overlooking bush setting
- Full main bathroom, plus guest powder room
- Reverse-cycle AC throughout
- Two lock-up garages, additional visitor parking
- Footsteps to Tuckwell Park and Lane Cove National Park

View

As advertised or by appointment

Agent

Lucy White

 0413 930 760

 lucy@morton.com.au

morton.com.au

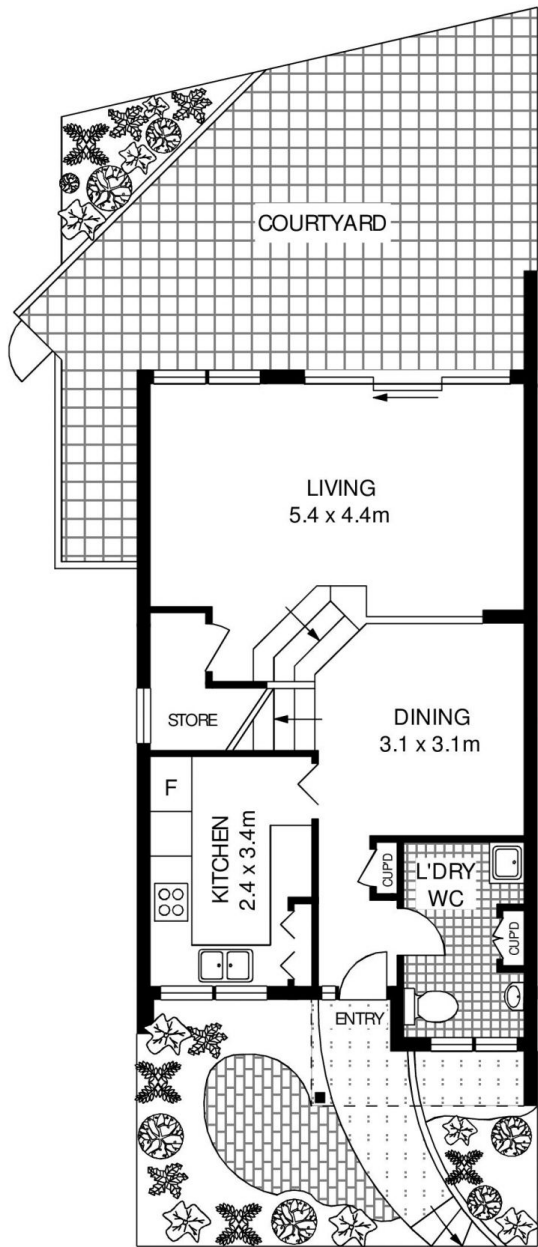

GROUND FLOOR

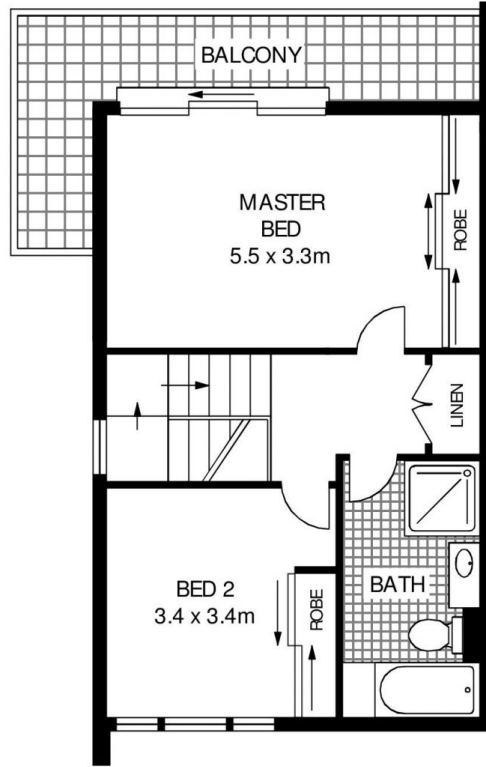

FIRST FLOOR

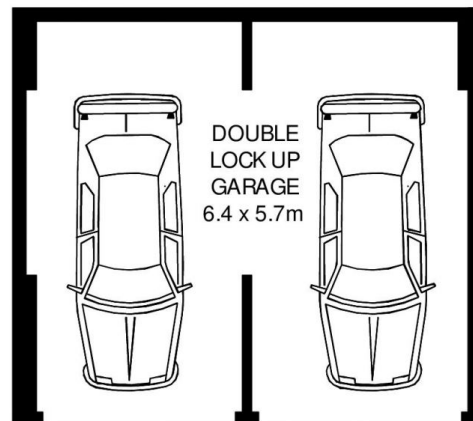

5/6 TUCKWELL PLACE

MACQUARIE PARK

SCAPE Floor Planning Disclaimer: This floor plan is conceptual only. It is provided for illustrative purposes only and should not be relied upon. We make no guarantee as to the correctness of this plan. All interested parties should make and rely on their own enquiries in determining the accuracy of the information contained in this floor plan.