



morton.

Hornsby 1605/88-90 George Street

 2  2  1

This modern and smartly appointed apartment represents an ideal chance to buy into the architectural 'Avanti' development that's supremely well located close to the heart of Hornsby. Instantly appealing thanks to its private upper floor position, it offers a superb living space with perfect convenience as it has all lifestyle amenities close at hand.

- Stylish and well-designed layout, air-conditioned throughout
 - Good-sized open living space plus a dedicated study area
 - A quality kitchen with stone benches and sleek gas cooking
 - Built-ins in both bedrooms, main has a WIR and ensuite
 - Lift access to a security car space; separate internal laundry
 - Covered balcony leads off the living room and main bedroom
- Pool, gym, spa, sauna and onsite building manager

View

As advertised or by appointment

Agents

Lucy White

 0413 930 760

 lucy@morton.com.au

Marcus Wynan

 0447 160 628

 marcus.wynan@morton.com.au

morton.com.au

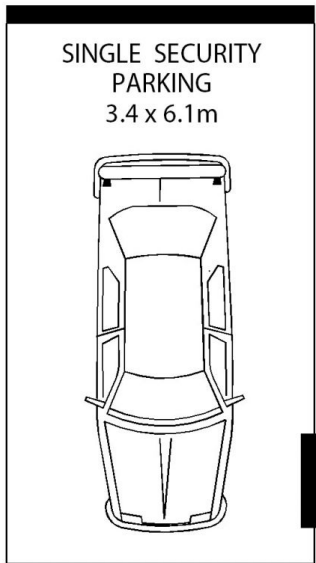
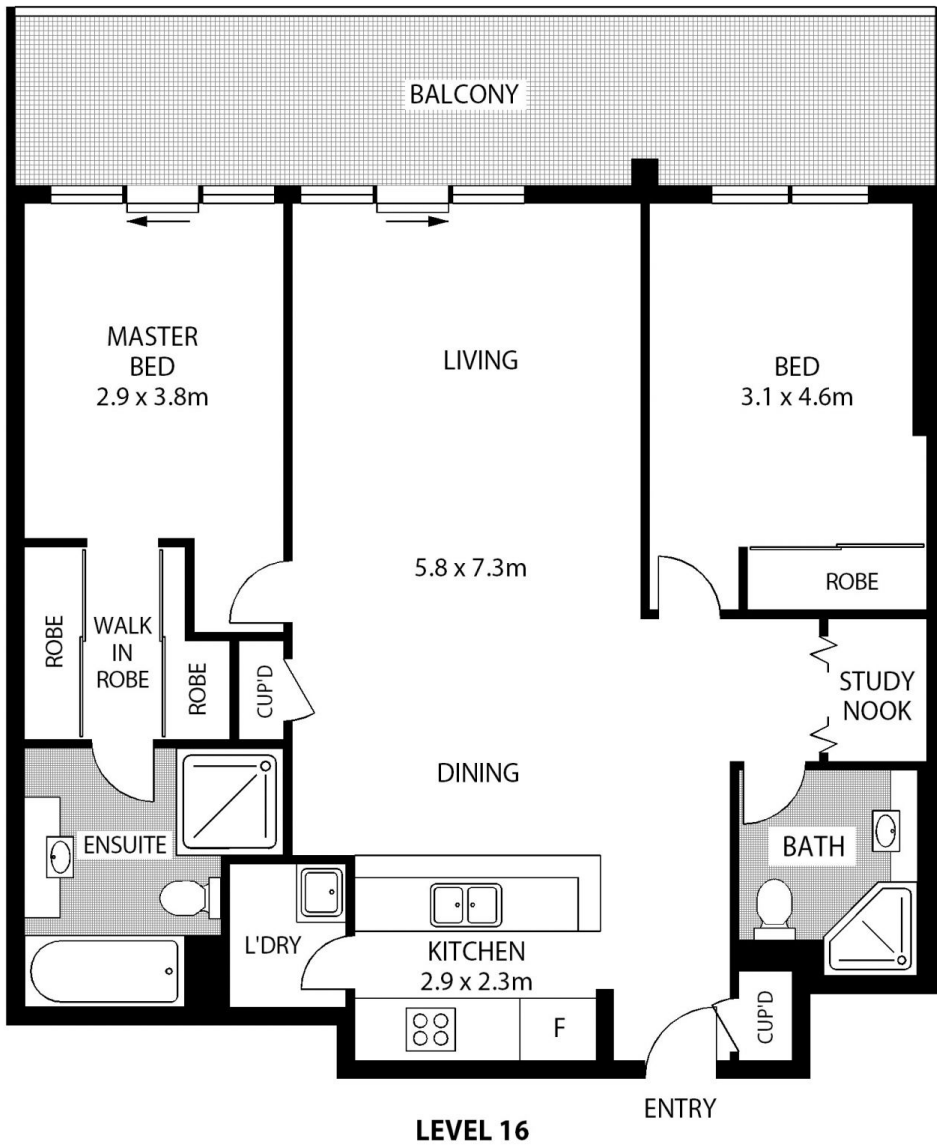

1605/88-90 GEORGE STREET

P1

HORNSBY

SCAPE Floor Planning Disclaimer: This floor plan is conceptual only. It is provided for illustrative purposes only and should not be relied upon. We make no guarantee as to the correctness of this plan. All interested parties should make and rely on their own enquiries in determining the accuracy of the information contained in this floor plan.