



morton.

Sydney 33/7 Macquarie Street

 2  2  2

Experience an exceptional harborside lifestyle within Sydney's coveted Bennelong tower, courtesy of this expansive corner apartment. This residence presents a distinctive on-the-water living experience, showcasing commanding and breathtaking panoramas from every window. Elevated to new heights, the flowing single-level design maximises space, bathes the interior in natural light, and offers unobstructed views spanning the harbour, Circular Quay, and the city skyline.

- Spectacular harbour scenes are captured from all major rooms
- Floor-to-ceiling walls of glass frame the magnificent outlooks
- A dual aspect layout with rear views over the Botanic Gardens
- Spacious open design features generous living and dining areas
- Two double bedrooms include a main that opens to a second balcony
- Quality modern kitchen with high-end finishes and excellent storage



morton.com.au

View



As advertised or by appointment

Agents

Ettiene West

 0410 593 749
 ettiene@morton.com.au

Arman Zounuzy

 0410 539 793
 arman.zounuzy@morton.com.au

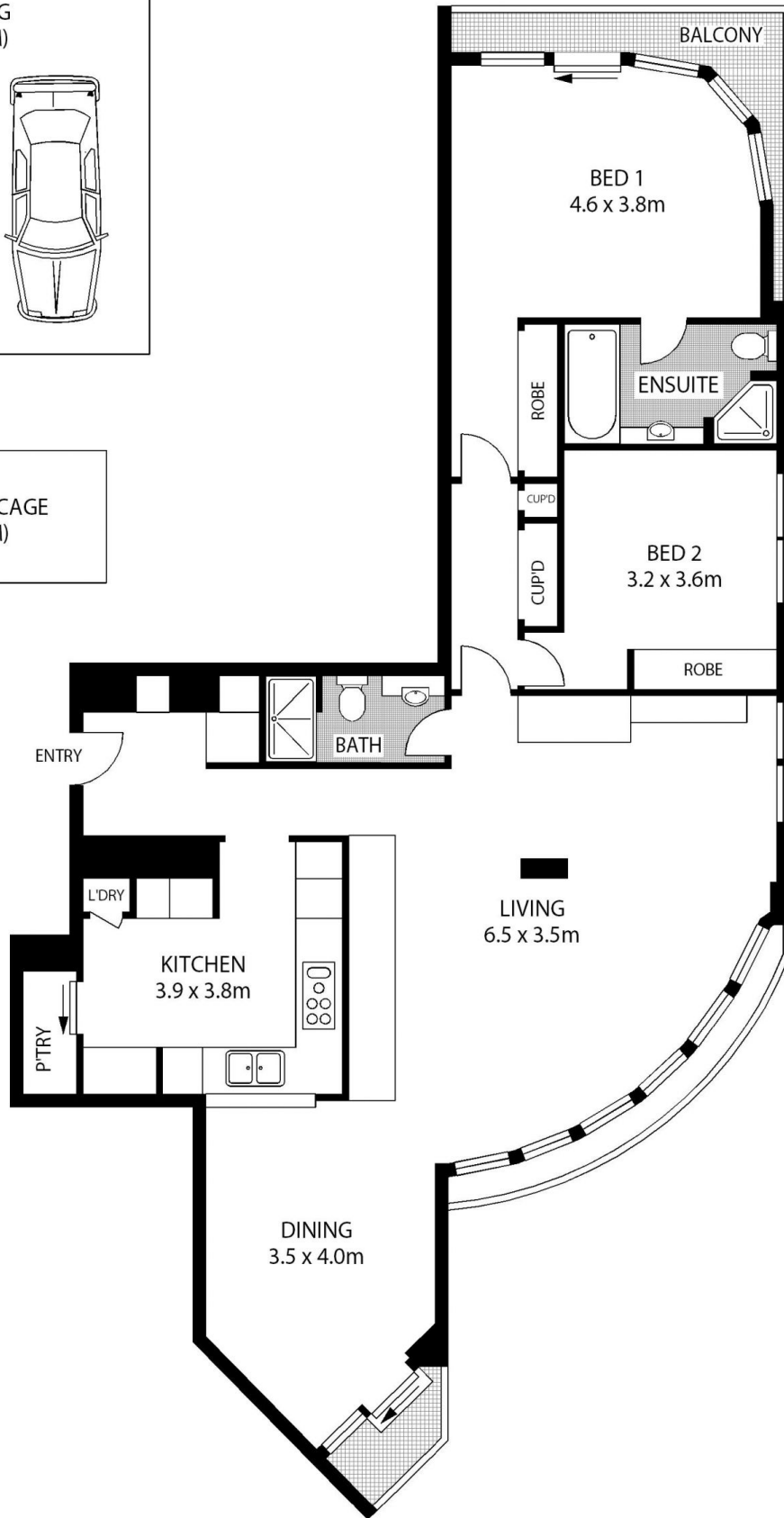
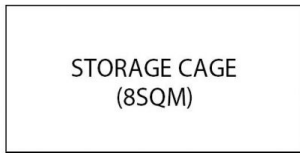
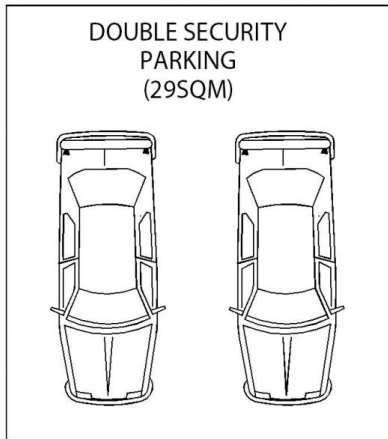

33/7 MACQUARIE STREET

SYDNEY

SCAPE Floor Planning Disclaimer: This floor plan is conceptual only. It is provided for illustrative purposes only and should not be relied upon. We make no guarantee as to the correctness of this plan. All interested parties should make and rely on their own enquiries in determining the accuracy of the information contained in this floor plan.