



morton.

Wentworth Point 642/30 Baywater Drive

 2  2  2

Promising a real sense of community as part of the popular The Waterfront development, this well-proportioned apartment delivers a spacious design along with sparkling water views over Homebush Bay. Its bright and airy layout has been well planned and easy resort lifestyle with abundance of natural light and a prime position in the Wentworth Point.



- Total size 150 sqm, Internal + Balcony 122 sqm
- Peaceful and private position with sweeping outlooks
- Spacious open layout with lounge, living and dining areas
- Direct level access to a sheltered terrace overlooking the bay
- Two bedrooms with built-ins leading to expansive balcony
- Open entertainer's kitchen and breakfast bar seating
- Full main bathroom, en-suite and separate internal laundry
- Two side-by-side car spaces with lift access to the front door
- Swimming pool and poolside area within the complex

View

As advertised or by appointment

Agents

Dylan Choe

 0416 932 977
 dylanchoe@morton.com.au

Akanksha Chaudhari

 0447 201 786
 akanksha@morton.com.au

morton.com.au



STORAGE
CAGE
ABOVE
CAR SPACE
2.4 x 0.8m

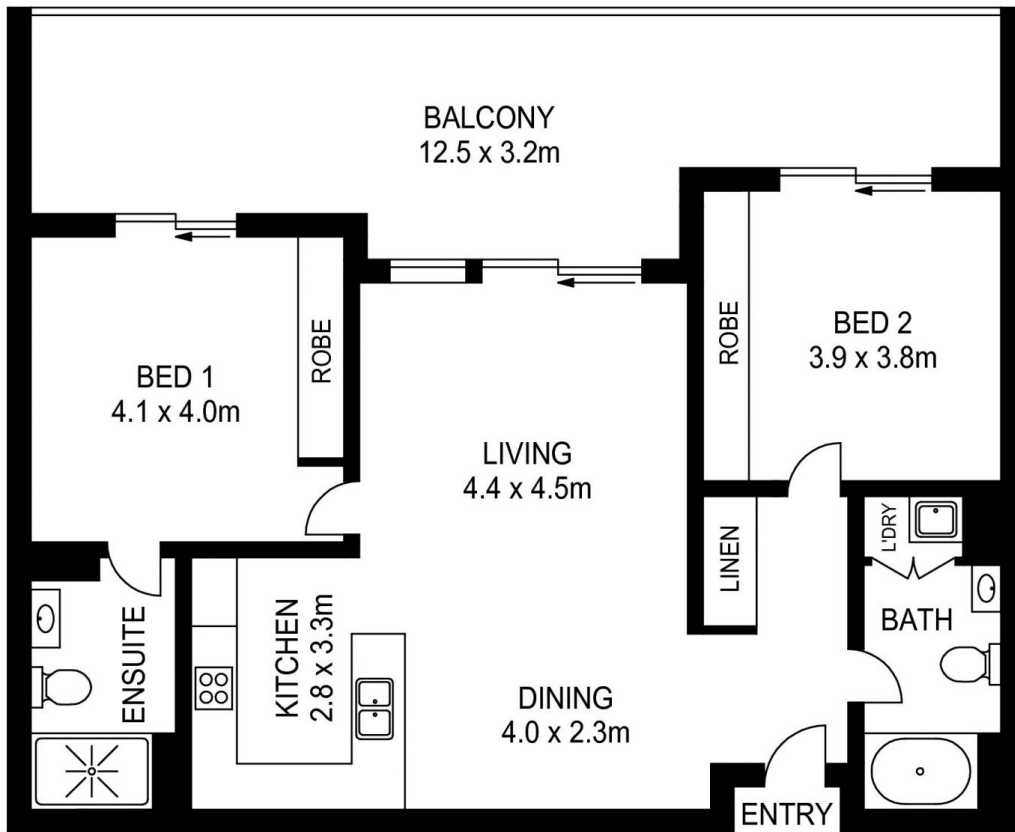
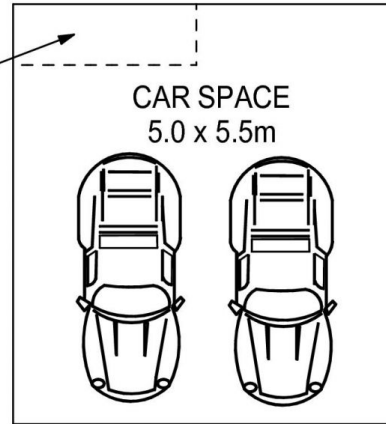

642/30 BAYWATER DRIVE, WENTWORTH POINT



www.assetphotographers.com.au

Please note these measurements are approximate only. The plans is intended as a rough guide for illustrative purpose. It is not warranted or guaranteed to be correct nor it is part of the sale or rental contract